

F3RE49

ANTEO F3RE49 AM SERIES SPECIFICATIONS			
MODEL		F3RE 49 EA62	F3RE 49 EA70
PLATFORM LENGTH	in	62	70
PLATFORM WIDTH	in	94	
WEIGHT	lb	1170	1213
CAPACITY	lb	4900	
CURRENT DRAW	amp	190	
FULL LOAD RAISE SPEED	in/s	3	
FULL LOAD LOWER SPEED	in/s	5	
HYDRAULIC FLUID TANK CAPACITY	gal	2.6	
MOTOR RATED HORSEPOWER	hp	2.1	
MAX. RELIEF VALVE SETTING	psi	2900	

LOAD CAPACITY AT DISTANCE (X) FROM THE EDGE OF PLATFORM (inches)									
(X)		0" ----- 24"	30"	35"	40"	45"	50"	55"	60"
F3RE49	LOAD CAPACITY (lbs)	4900	4070	3410	3025	2695	2310	2225	2145

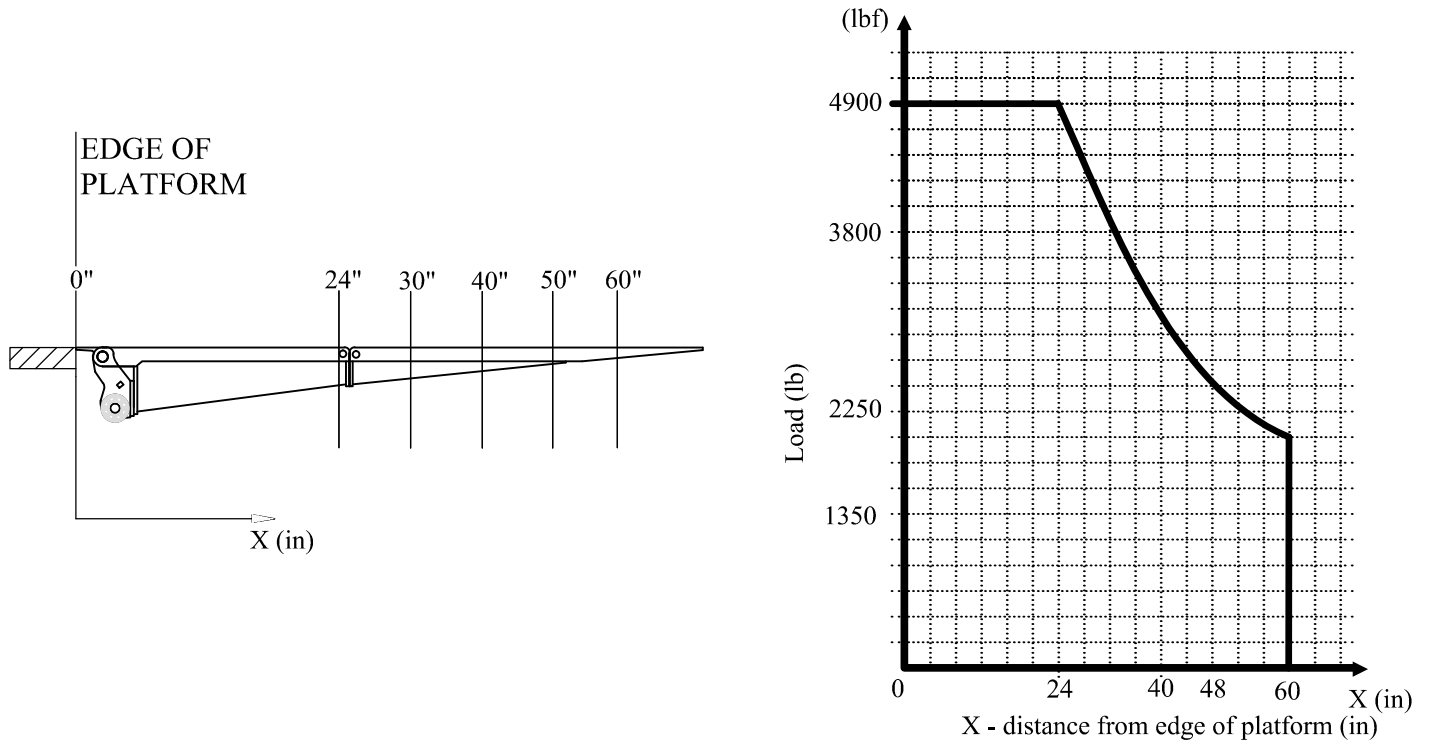

Figure 1 : F3RE49 Load Capacity

Table 1: Platform Options.

F3RE49 HS							
Model	Platform Length (B)	J	K	Taper	Minimum Bed Height (D)	Maximum Bed Height (D)	Gate Weight
F3RE 49 EA62	62"	23.5"	38.5"	0"	43"	60"	1170 Lbs
F3RE 49 EA70	70"	29.5"	40.5"				1213 Lbs

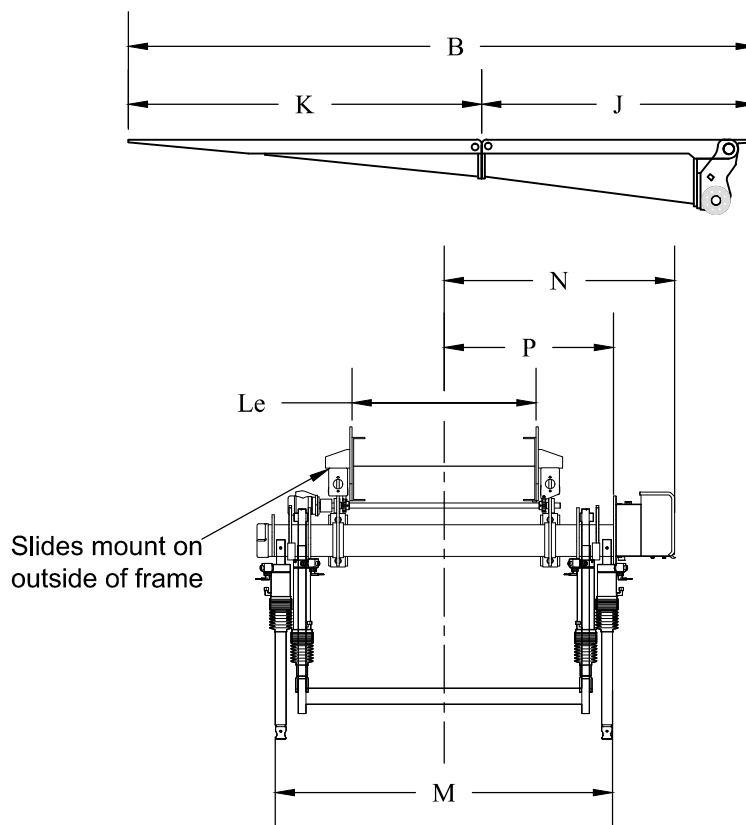
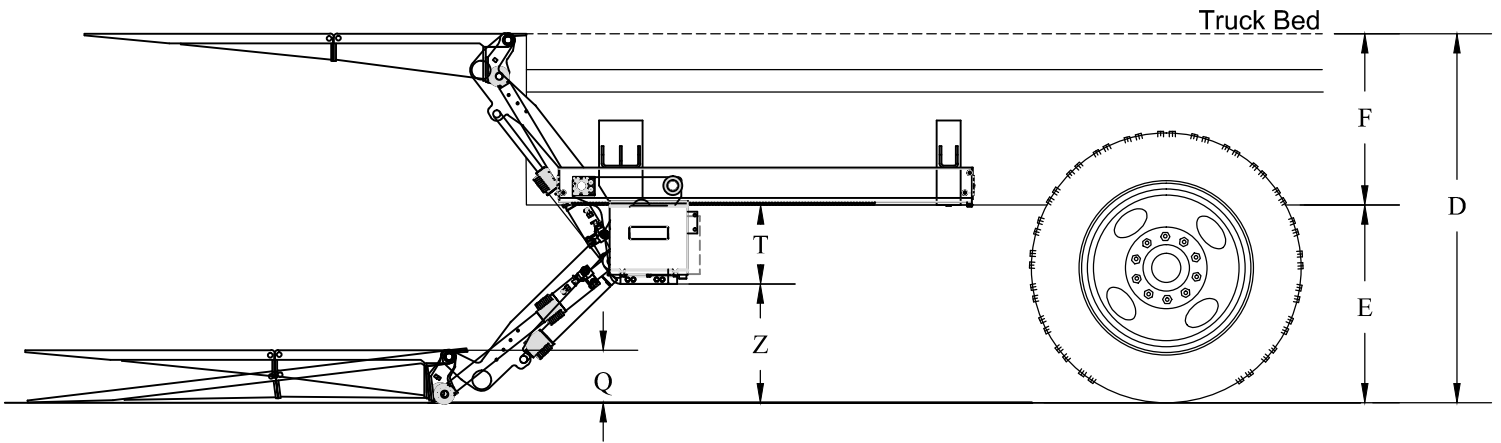

Figure 2 : For Use With Table 2 And Table 3

SIDE VIEW - LIFTGATE DEPLOYED



SIDE VIEW - LIFTGATE STOWED

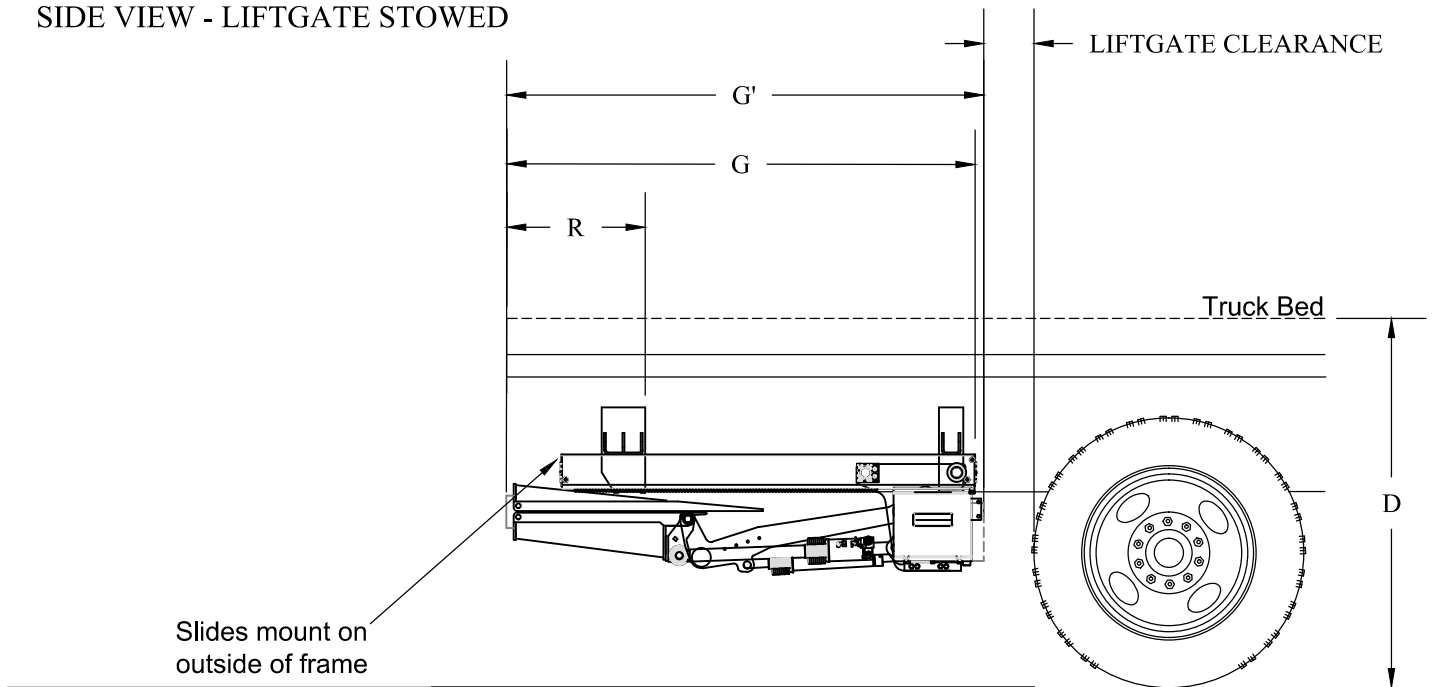

Figure 3 : For Use With Table 2 and Table 3

F3RE49

Table 2: Installation Dimensions.

F3RE49 HS - 4900 Lbs															
D- BED HEIGHT	E		F		R	Z	G	G'	Le		P	Q	M	N	T
min. 43 max. 60	min	max	min	max			min	min	max	min				min	
	26.0	35.0	17.0	25.0	Table 3	Z= E - 13	75.79	78.15	34.2	29.5	29.5	9.2	58.70	40.7	13.0
	Measure		F= D - E												
All dimensions in inches															
E: distance between the bottom of the frame and the ground															
F: Combined height of Body Bed + Long Sills + Truck Frame + Sub Frame (trailers): F= D - E															
R: Recomend installation position dimension determined from installation instruction "Table for extrapolation of distance R"															
Z (ground clearance): distance between the ground and the lowest part of the trunion: Z = E - 13															
G: distance between back of the truck and the end of the rail guide															
G': distance between the back of the truck and the end of the power unit															

Table 3: Table for extrapolation of distance R

F	R	F	R
25.00	18.85	20.87	23.09
24.80	19.09	20.67	23.26
24.61	19.32	20.47	23.42
24.41	19.55	20.28	23.59
24.21	19.78	20.08	23.75
24.02	20.00	19.88	23.91
23.82	20.22	19.69	24.06
23.62	20.43	19.49	24.22
23.43	20.64	19.29	24.37
23.23	20.85	19.09	24.52
23.03	21.05	18.90	24.67
22.83	21.25	18.70	24.81
22.64	21.44	18.50	24.96
22.44	21.64	18.31	25.10
22.24	21.83	18.11	25.24
22.02	22.02	17.91	25.38
21.85	22.20	17.72	25.52
21.65	22.39	17.52	25.65
21.46	22.56	17.32	25.78
21.26	22.74	17.13	25.91
21.06	22.92	17.00	25.99

INSTRUCTIONS TO DETERMINE IF F3RE FITS ON THE TRUCK OR TRAILER

Follow the steps below to find the key dimensions for fitting the gate and complete Table 4, in order to determine if the gate will fit on the truck or trailer. **ALL THE DIMENSIONS** found for Table 4 must be in accordance with the MIN-MAX column for the gate to fit.

STEP 1) Measure bed height (D dimension).

STEP 2) Measure distance between the bottom of the truck or trailer frame and ground (E dimension).

STEP 3) Calculate combined height of Body Bed + Long Sills + Truck Frame + Sub Frame (trailers): $F = D - E$

STEP 4) Measure horizontal clearance from the back of the truck or trailer along the frame to spring shackle or other obstruction (G dimension). This will determine if the slides fit.

STEP 5) Measure distance between the back of the truck or trailer to the first obstruction under the frame level (G' dimension). This will determine if the gate mechanism and frame will fit.

STEP 6) Measure outside width of truck or trailer frame (Le dimension).

STEP 7) Measure body width dimension to make sure the platform width does not exceed it.

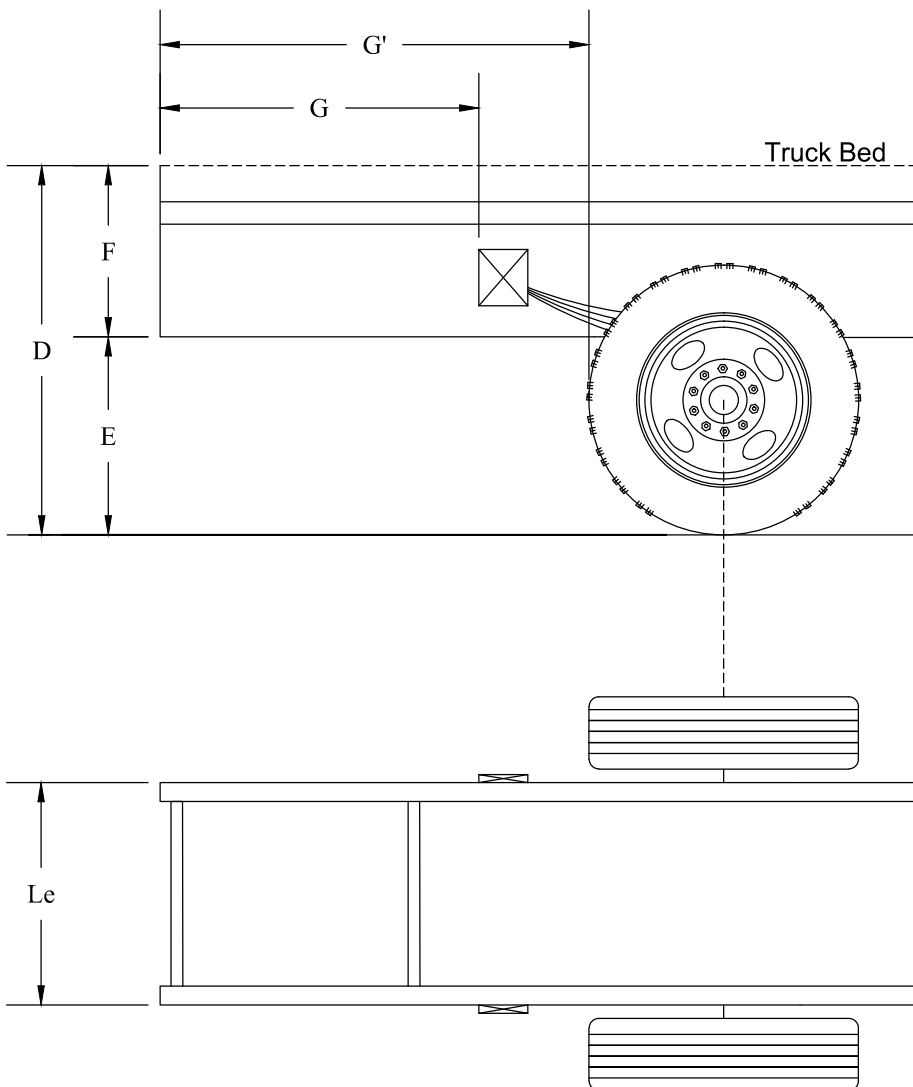

Table 4: F3RE49 HS - Key Dimensions

Dimension	Dimension Found	MIN - MAX
D		43" - 60"
E		26" - 35"
F		17" - 25"
G		min 75.79" clearance required
G'		min. 78.15" clearance required
Le		29.5" - 34.2"