

ANTEO REP 33/1 SERIES SPECIFICATIONS			
MODEL		REP 33 EA48	REP 33 EA56
PLATFORM LENGTH	in	48	56
PLATFORM WIDTH	in	78	
WEIGHT*	lb	620	648
CAPACITY	lb	3300	
CURRENT DRAW	amp	160	
FULL LOAD RAISE SPEED	in/s	3	
FULL LOAD LOWER SPEED	in/s	5	
HYDRAULIC FLUID TANK CAPACITY	gal	1.5	
MOTOR RATED HORSEPOWER	hp	2.1	
MAX. RELIEF VALVE SETTING	psi	2538	
* Weight does not include bed extension and bumper. Add 81 Lbs for bumper weight.			

LOAD CAPACITY AT DISTANCE (X) FROM THE EDGE OF PLATFORM (inches)									
(X)		0" ----- 24"	30"	35"	40"	45"	50"	55"	60"
REP 33/1	LOAD CAPACITY (lbs)	3300	2560	2300	2025	1800	1630	1460	1350

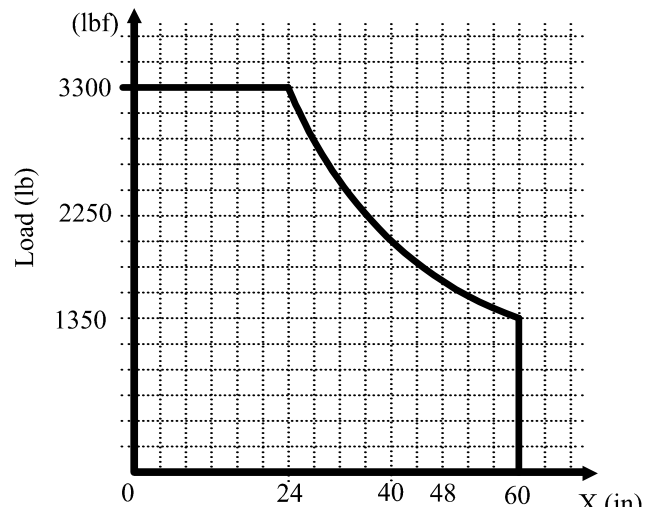
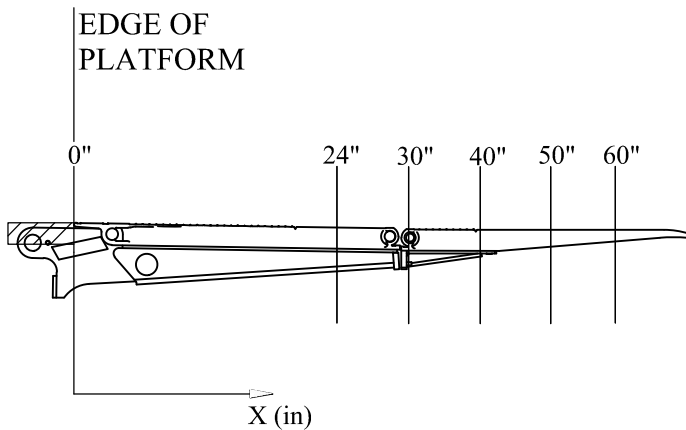

Figure 1: REP 33/1 Load Capacity X - distance from edge of platform (in)

REP 33/1 Info took from Anteo installation instructions

Table 1: Platform Options.

REP 33/1 H							
Model	Platform Length (B)	J	K	Taper	Minimum Bed Height (D)	Maximum Bed Height	Gate Weight*
REP 33 EA48	48"	25"	23"	0"	38"	59"	620 Lbs
REP 33 EA56	56"	29"	27"	0"	42"	59"	648 Lbs

* Weight does not include bed extension and bumper. Add 81 Lbs for bumper weight.

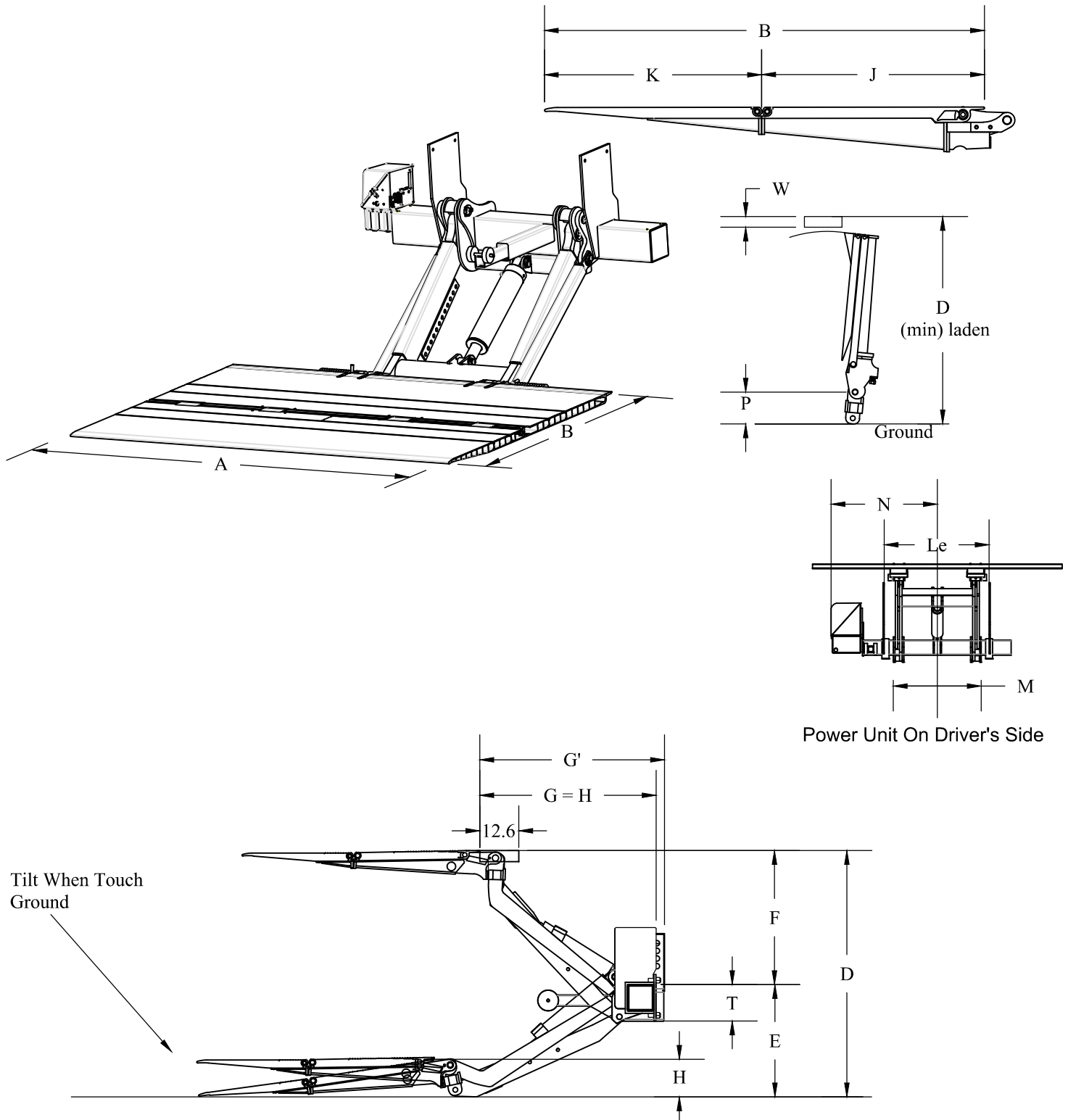

Figure 2 : For Use With Table 2

REP 33/1 - Info taken from Anteo REP 1 installation instructions

Table 2: Installation Dimensions.

REP 33/1 H - 3300 Lbs												
D- BED HEIGHT (LOADED)	E	F	G	G'	Le		H	M	N	T	P	W
					max	min						
38	20.5	17.5	44.38	46.88	37.4	31.5	6.8	30.8	72.8	13.8	5.8	3.9
39	20.5	18.5	43.75	46.25								
40	20.5	19.5	43.00	45.5								
41	20.5	20.5	42.28	44.78								
42	20.5	21.5	41.40	43.9								
43	20.5	22.5	40.50	43.00								
44	20.5	23.5	39.57	42.07								
45	21.5	23.5	39.57	42.07								
46	22.5	23.5	39.57	42.07								
47	23.5	23.5	39.57	42.07								
48	24.5	23.5	39.57	42.07								
49	25.5	23.5	39.57	42.07								
50	26.5	23.5	39.57	42.07								
51	27.5	23.5	39.57	42.07								
52	28.5	23.5	39.57	42.07								
53	29.5	23.5	39.57	42.07								
54	30.5	23.5	39.57	42.07								
55	31.5	23.5	39.57	42.07								
56	32.5	23.5	39.57	42.07								
57	33.5	23.5	39.57	42.07								
58	34.5	23.5	39.57	42.07								
59	35.5	23.5	39.57	42.07								

All dimensions in inches

G: distance between the platform and the end of the bracket

G': distance between the platform and the end of the power unit

H: distance between the platform and the back of the trunion (H = G)

REP 33/1 Info taken from Anteo installation instructions

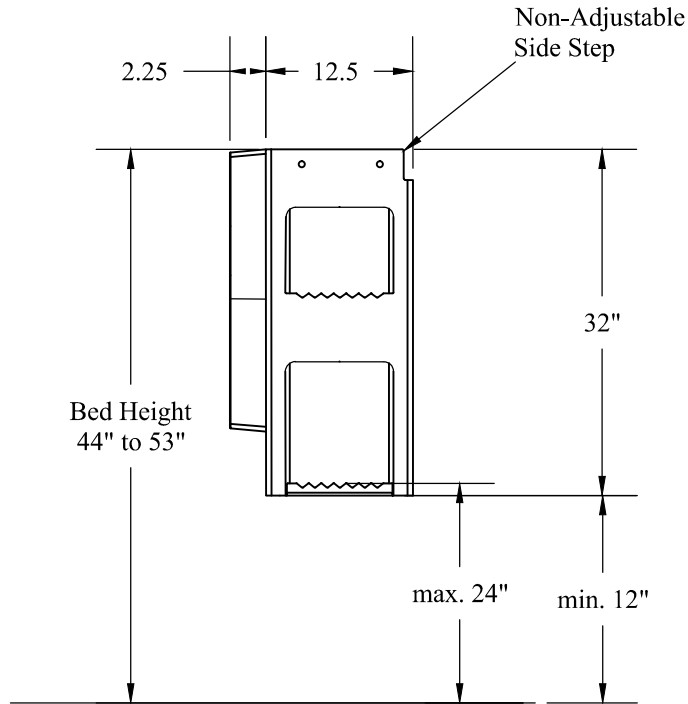

Figure 3 : REP 33 Side Step

Table 3: Bed Extension and Side Steps

REP33/1 BED EXTENSION & SIDE STEP					
V	X	Y	SPACERS WEIGHT	SIDE STEP WEIGHT	BED EXTENSION WEIGHT
BED EXTENSION STD. WIDTH	SPACERS WIDTH (SET OF TWO)	SIDE STEP WIDTH (SET OF TWO)			
87.5"	5.5"	5.0"	26.6 Lbs	76.2 Lbs	224 Lbs

Table 4: Finishing

PARTS FINISHING	
BED EXTENSION	GALVANIZED
SPACERS	GALVANIZED
SIDE STEPS	GALVANIZED

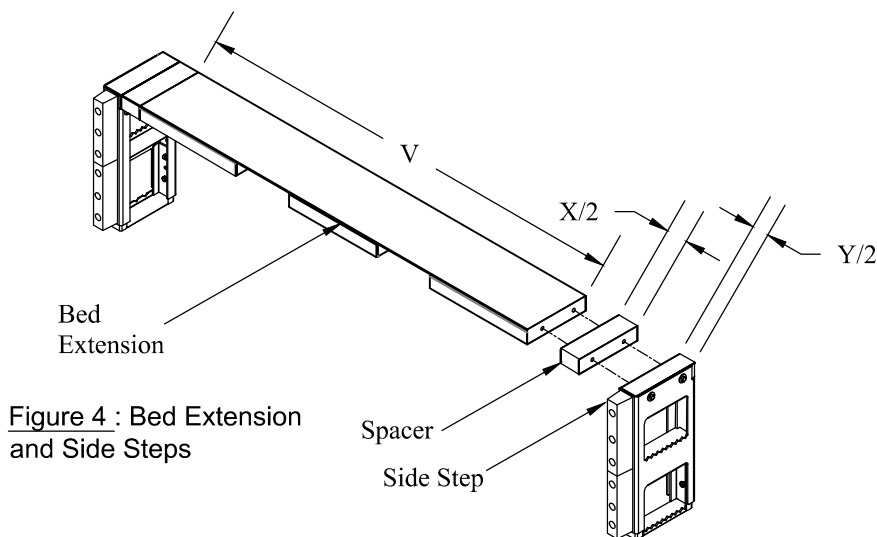

Figure 4 : Bed Extension and Side Steps

Table 5: Width

POSSIBLE WIDTH COMBINATIONS		TOTAL LENGTH	TRUCK BODY WIDTH
COMBINATION 1)	BED EXTENSION + SIDE STEP	92.5"	96"
COMBINATION 2)	BED EXTENSION + SPACERS + SIDE STEP	98"	102"