

ANTEO REP 44/2 SERIES SPECIFICATIONS			
MODEL		REP44 EA56	REP 44EA62
PLATFORM LENGTH	in	56	62
PLATFORM WIDTH	in	86	
WEIGHT*	lb	905	993
CAPACITY	lb	4400	
CURRENT DRAW	amp	180	
FULL LOAD RAISE SPEED	in/s	3	
FULL LOAD LOWER SPEED	in/s	5	
HYDRAULIC FLUID TANK CAPACITY	gal	1.7	
MOTOR RATED HORSEPOWER	hp	2.1	
MAX. RELIEF VALVE SETTING	psi	2755	
* Weight does not include bed extension and bumper. Add 63 Lbs for bumper weight.			

LOAD CAPACITY AT DISTANCE (X) FROM THE EDGE OF PLATFORM (inches)									
(X)		0" ----- 24"	30"	35"	40"	45"	50"	55"	60"
REP 44/2	LOAD CAPACITY (lbs)	4400	4070	3410	3080	2695	2310	2090	1925

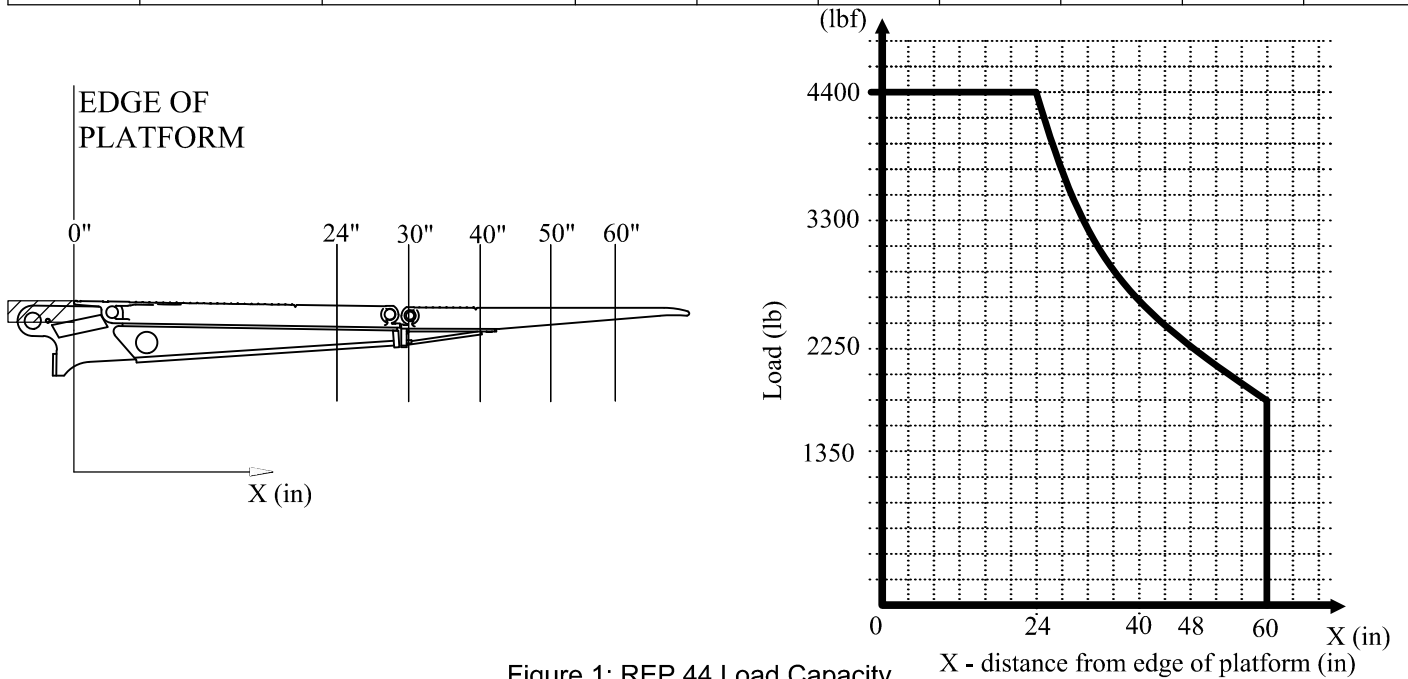

Figure 1: REP 44 Load Capacity

X - distance from edge of platform (in)

REP 44 Info taken from Anteo installation instructions

Table 1: Platform Options.

REP 44/2 H							
Model	Platform Length (B)	J	K	Taper	Minimum Bed Height (D)	Maximum Bed Height	Gate Weight*
REP44 EA56	56"	29.5"	26.5"	0"	43"	59"	905 Lbs
REP 44EA62	62"	31.5"	30.5"	0"	46"	59"	993 Lbs

* Weight does not include bed extension and bumper. Add 63 Lbs for bumper weight.

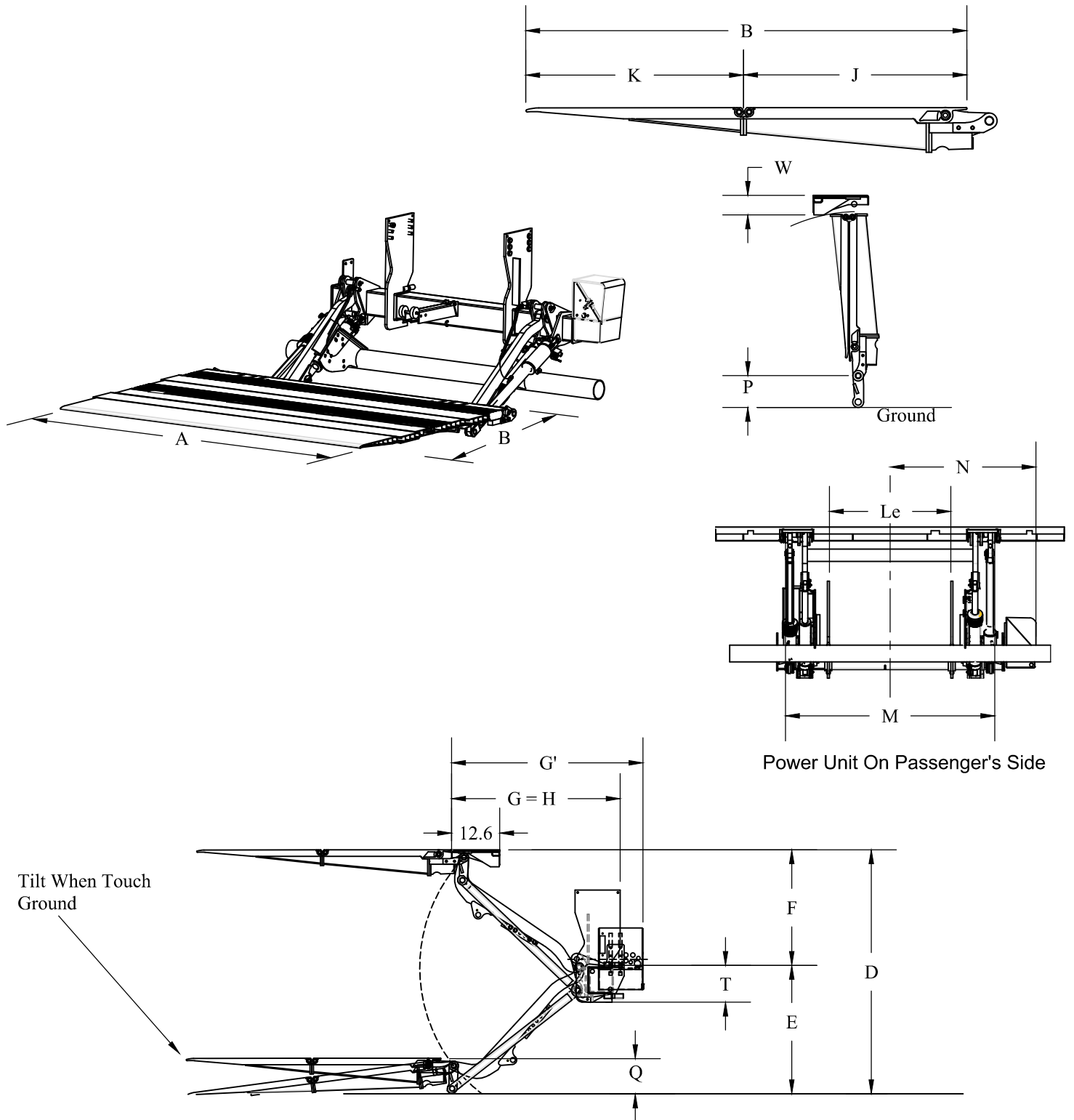

REP 44 Info taken from Anteo installation instructions

Table 2: Installation Dimensions.

REP 44/2 H 4400 Lbs												
D- BED HEIGHT (LOADED)	E	F	G	G'	Le		Q	M	N	T	P	W
					max	min						
43	24	19	48.16	53.718	27.5	38.2	8.6	58.5	89.8	8.3	6.8	4.2
44	24	20	47.65	53.205								
45	24	21	47.11	52.666								
46	24	22	46.53	52.09								
47	24	23	45.93	51.486								
48	24	24	45.29	50.847								
49	24	25	44.59	50.144								
50	24	26	43.82	49.38								
51	24	27	43.00	48.557								
52	24	28	42.14	47.694								
53	24	29	41.25	46.807								
54	25	29	41.25	46.807								
55	26	29	41.25	46.807								
56	27	29	41.25	46.807								
57	28	29	41.25	46.807								
58	29	29	41.25	46.807								
59	30	29	41.25	46.807								
All dimensions in inches												
G: distance between the platform and the end of the bracket												
G': distance between the platform and the end of the power unit												
H: distance between the platform and the back of the trunion (H = G)												

REP 44 Info taken from Anteo installation instructions

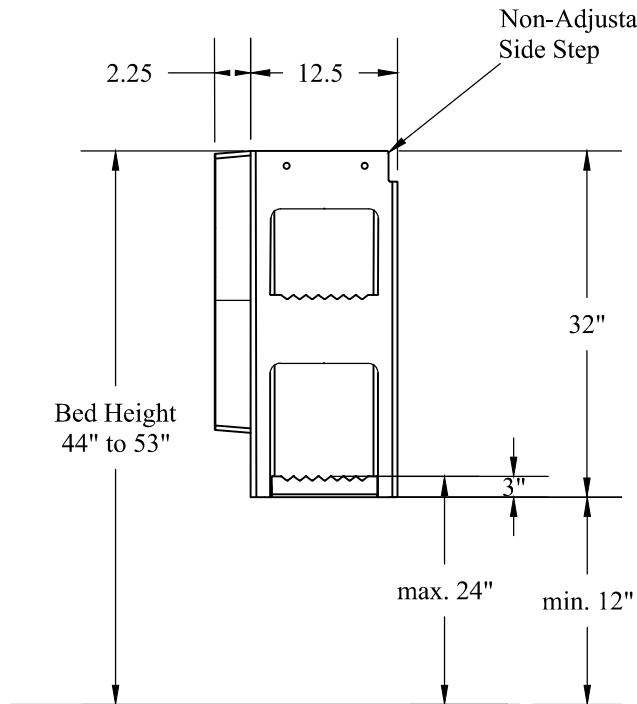

Figure 3 : REP 44/2 Side Step

Table 3: Bed Extension and Side Steps

REP44/2 BED EXTENSION & SIDE STEP			
V	Y	SIDE STEP WEIGHT	BED EXTENSION WEIGHT
BED EXTENSION STD. WIDTH	SIDE STEP WIDTH (SET OF TWO)		
96.5"	5.0"	76.2 Lbs	205 Lbs

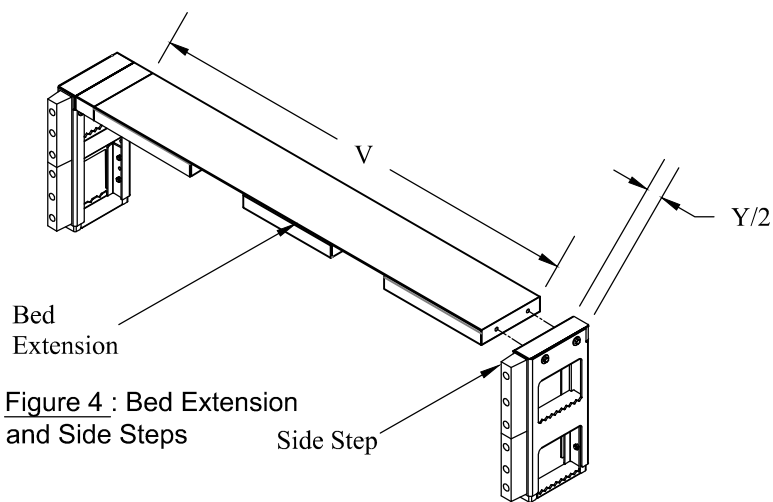

Figure 4 : Bed Extension and Side Steps

Table 4: Finishing

PARTS FINISHING	
BED EXTENSION	GALVANIZED
SIDE STEPS	GALVANIZED

Table 5: Width

POSSIBLE WIDTH COMBINATIONS		TOTAL LENGTH	TRUCK BODY WIDTH
COMBINATION 1)	BED EXTENSION + SIDE STEP	101.5"	102"